

AUTOMATIC ROLLSTOCK BAGGING & SEWING MACHINE

HAS

The Automatic bagging & sewing machine provides a fast and efficient system of filling bags and closing them using high quality sewing equipment. By the usage of a uniquely designed moving orifice system, the machine is known for a quick and reliable filling process while also handling the product in a gentle way. The HAS is designed for more conservative budgets with manual adjustments depending on the desired roll stock bag size. This makes it the ideal machine for fast and continues packaging using consistent weights and sizes.

- ✓ Gentle and efficient product handling
- ✓ Suitable for high variety of packaging sizes
- ✓ Suitable for high variety of products
- ✓ Reliable design
- ✓ Customizable for your specific situation



Suitable packaging type

Roll stock mesh bags

Packing range

2,5kg - 25kg

Capacity (bags/hr)

2,5 - 5 kg: 1250 bags/hr

5 - 12,5 kg: 1100 bags/hr

12,5 - 25 kg: 1000 bags/hr

Weight of machine

± 1000 kg

Power consumption

± 5,5 kW

Voltage

3x 400V/230V, -0- + ground, 50 Hz

3x 480/277V, -0- + ground, 60 Hz

Air consumption

± 25 l/min, 8 bar

Options/Upgrades

- Along-moving side supports
- Vibrating unit for better settlement
- Certificate-dispenser
- Configurable Sewing-head
- Sewing thread break-detection
- Sewing needle break-detection
- Lint break-detection
- Broken bag detection

Recommended combinations

MHW

HAS SCHEMATIC VIEW

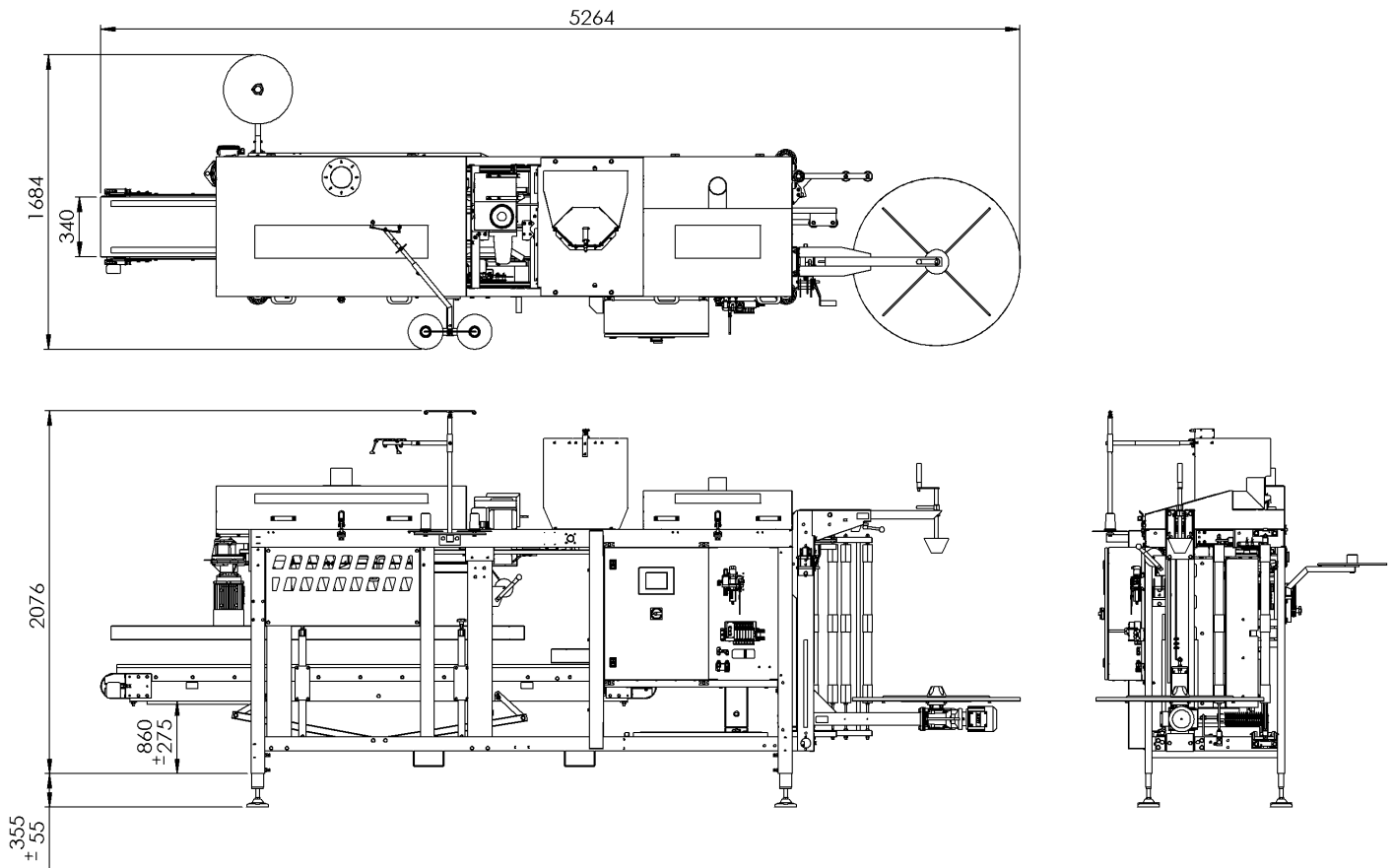

Recommended combination
HAS + MHW

