

MULTI HEAD WEIGHER DOUBLE ROW

MHW12



The Multi Head Weigher 12 is a double row weigher with a smaller design for the budget conscious customer who is looking for a precise and fast machine that can be easily integrated with their existing line. With the many customizable and adjustable features, the machine can be accurately set-up and fine-tuned according to your product type, capacity and demands. The MHW12 is known for its high-precision and speed ratio.

- ✓ Self-learning and adjusting product flow efficiency
- ✓ Suitable for high precision and high speed operation
- ✓ Adjustable speed/precision ratio for the best efficiency in all situations
- ✓ Gentle product handling
- ✓ Smart, User-friendly and reliable design
- ✓ Customizable for the best efficiency according to your specific situation

Discharge systems

- ✓ Side discharge - Single belt system
- ✓ Side discharge - Double belt system

Weighing range (discharge units):
1 - 50 kg

2,5 kg	1350 - 1500
5 kg	1350 - 1450
10 kg	1300 - 1450
15 kg	1275 - 1400
25 kg	1200 - 1375
50kg	650 - 700

Power consumption
± 2,87 kW

Air consumption
± 6,6 l/discharge, 6-7 bar

Voltage
3x 400V/230V, -0- + ground, 50 Hz
3x 480/277V, -0- + ground, 60 Hz

Capacity/Discharge system
(discharges per hour)

Single bi-directional belt
1 kg 1350 - 1500

Double bi-directional belt	
1 kg	1900 - 2400
2,5 kg	1870 - 2400
5 kg	1800 - 2200
10 kg	1500 - 2000
15 kg	1450 - 1850
25 kg	1400 - 1750
50 kg	850 - 1020

Options/Upgrades

- Configurable discharge systems
- Configurable weighing-buckets
- Configurable product seals & guidance
- Configurable product-detection & sensor systems
- Optional soft-landing
- Optional crate discharge system
- Optional operators platform

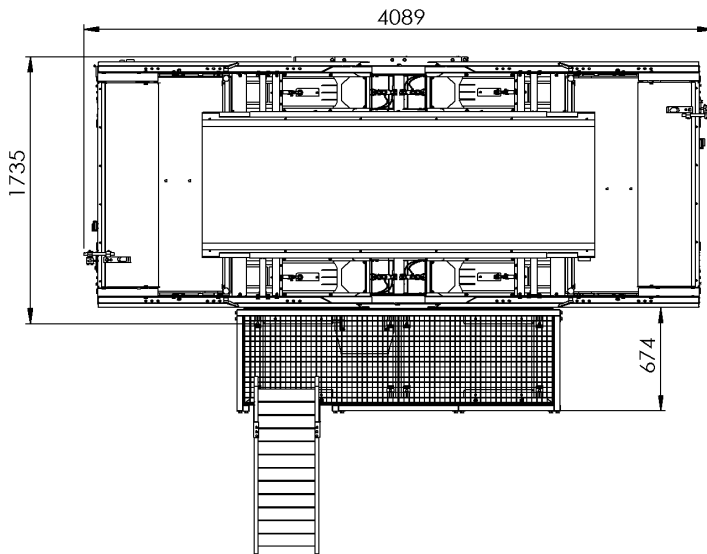

MHW12 SCHEMATIC VIEW

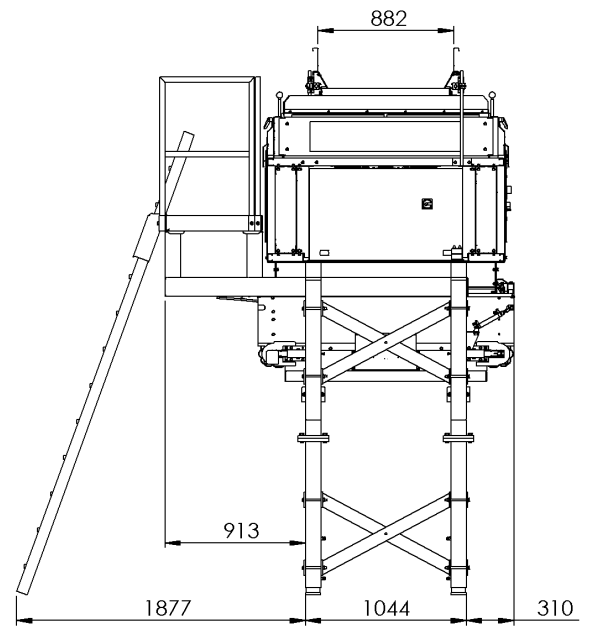
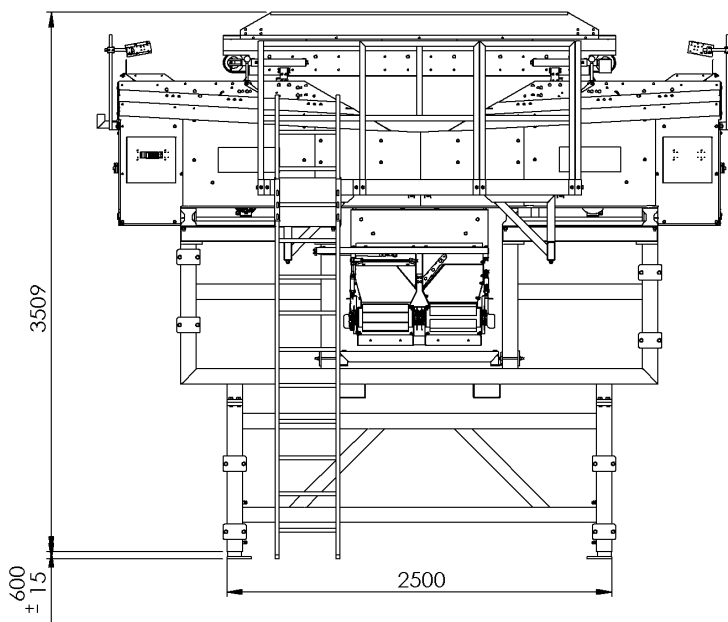

Recommended combination
MHW12 + ABP + SAS + HAS + BFL

