

# MULTI HEAD WEIGHER SINGLE ROW

MHW10



The Multi Head Weigher 10 is a single row weigher with a compact design that can be easily intergraded to the rest of your existing line. The MHW10 contains a lot of customizable and adjustable features to offer you the most efficient weighing process according to your product and your priorities.

- ✓ Self-learning and adjusting product flow efficiency
- ✓ Suitable for both high precision and high speed operation
- ✓ Adjustable speed/precision ratio for the best efficiency in all situations
- ✓ Gentle product handling
- ✓ Smart, User-friendly and reliable design
- ✓ Customizable for the best efficiency according to your specific situation

#### Discharge systems

- ✓ Side discharge - Single belt system
- ✓ Side discharge - Double belt system
- ✓ Mid front discharge

Weighing range (discharge units):  
1 – 50 kg

Power consumption  
± 2,5 kW

Air consumption  
± 5,5 l/discharge, 6-7 bar

Voltage  
3x 400V/230V, -0- + ground, 50 Hz  
3x 480/277V, -0- + ground, 60 Hz

Capacity/Discharge system  
(discharges per hour)

Single bi-directional belt  
1 kg 1225 - 1375

2,5 kg 1200 - 1350

5 kg 1150 - 1300

10 kg 900 - 1025

15 kg 850 - 960

25 kg 800 - 900

50 kg 500 - 600

Double bi-directional belt

1 kg 1230 - 1385

2,5 kg 1250 - 1375

5 kg 1225 - 1375

10 kg 1125 - 1350

15 kg 1050 - 1340

25 kg 1000 - 1320

50 kg 620 - 725

Frontal discharge

1 kg 1900 - 2450

2,5 kg 1850 - 2400

5 kg 1800 - 2350

10 kg 1450 - 1850

Options/Upgrades

- Configurable discharge systems
- Configurable weighing-buckets
- Configurable product seals & guidance
- Configurable product-detection & sensor systems
- Optional soft-landing
- Optional crate discharge system
- Optional operators platform

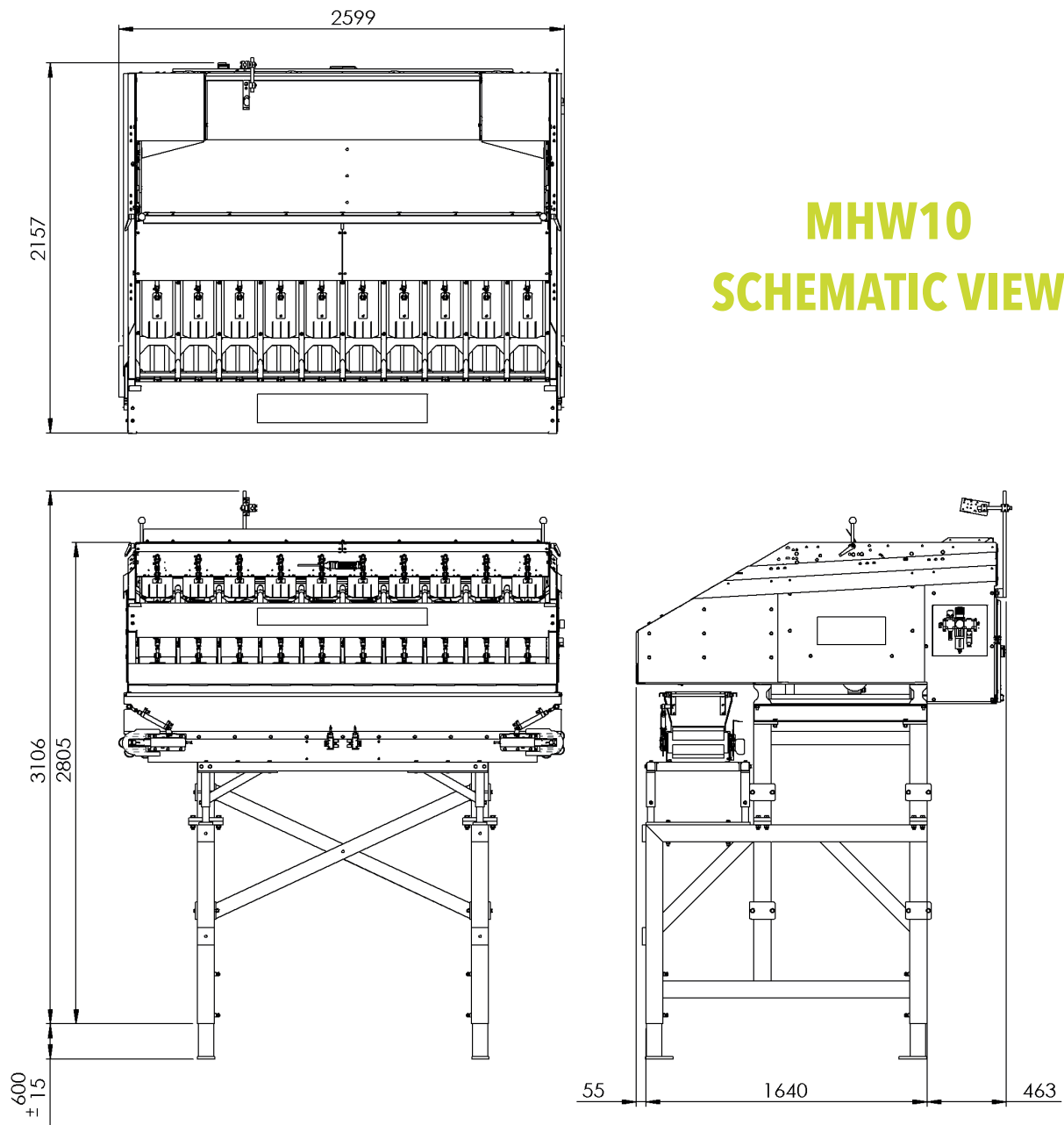

**Recommended combination**  
MHW10 + ABP + SAS + HAS + BFL

